

# PETITTO MULE<sup>®</sup>

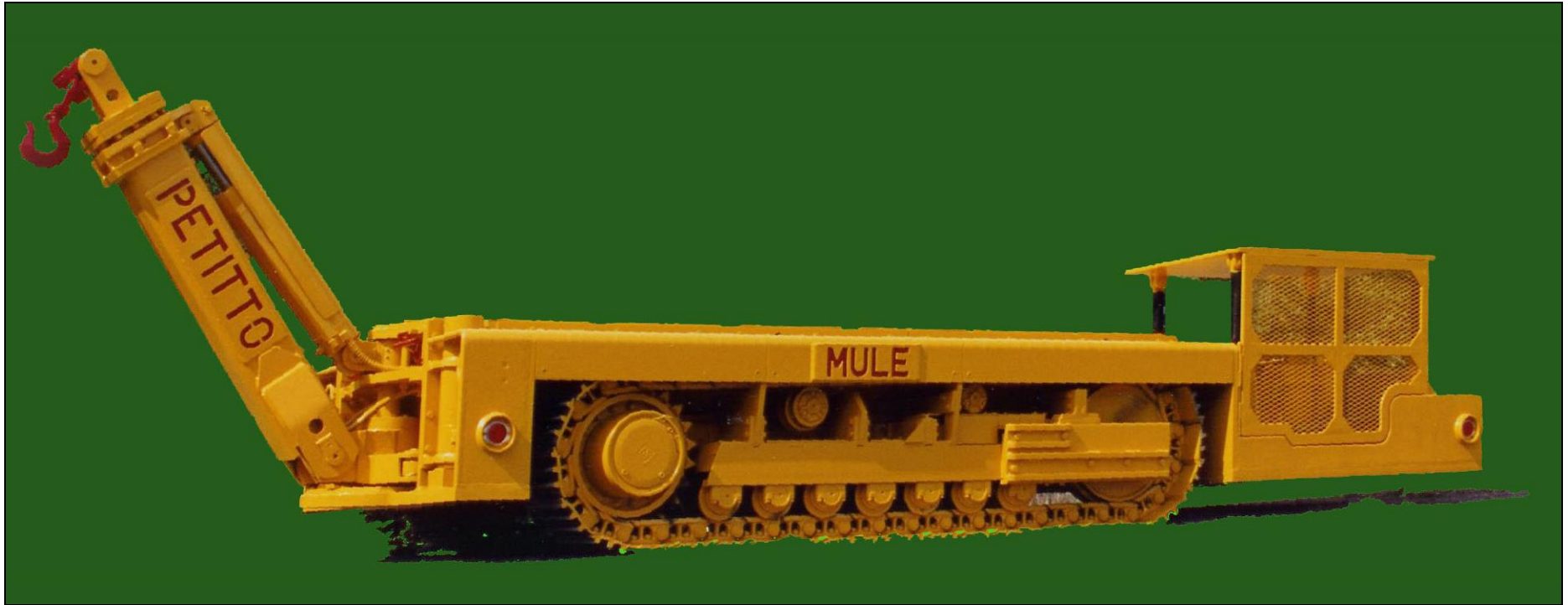

**LONGWALL SHIELD RETRIEVER AND  
GENERAL UTILITY TRACTOR  
ELECTRIC MODEL 1036 & MODEL 1039**

**Petitto Mine Equipment, Inc.**

P.O. Box 758

East Brockway & Hirschman

Morgantown, West Virginia 26507-0758 US

Phone (304) 292-3936

Fax (304) 292-6023

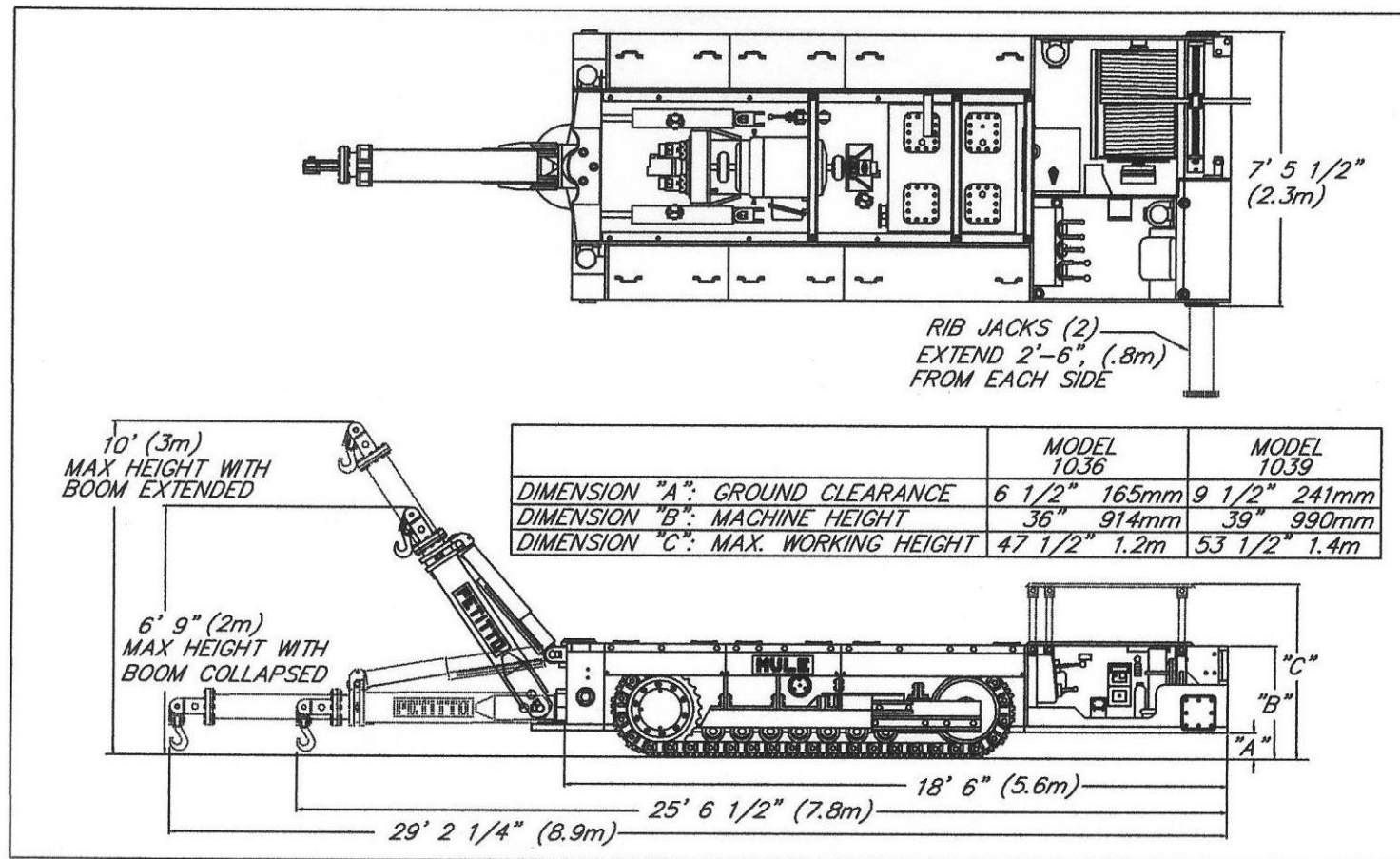

## Specifications

**460/575 VAC (Dual)**  
**100 hp Motor**  
**700' Trailing Cable (213.4m)**  
**550' Cable Reel Capacity (167.6m)**  
**Option 700' Cable Reel Capacity (213.4m)**  
**#2/3 Cond. G-GC 1.34" O.D. (34mm)**  
**MSHA Approved**  
**MSHA S.T. & E. Approved**

**Quartz Halogen Headlights (4)**  
**Automatic Fire Suppression**  
**Certified Canopy**  
**Rib Jacks (2)**  
**Stab Jacks (4)**  
**16" Grouser Pads (406mm)**  
**Boom Extends & Swings 90°**  
**Weight – 22 Ton (20tonne)**